

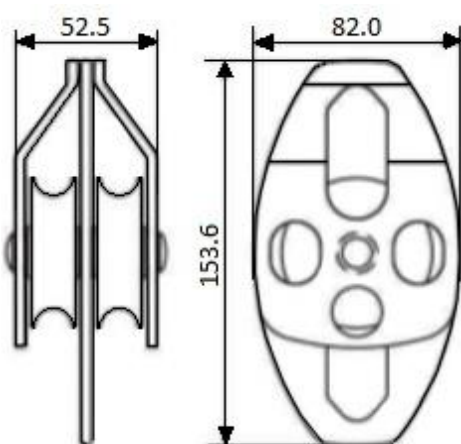

TECHNICAL SHEET FA 70 017 01

DOUBLE PULLEY WITH MOVEABLE FLANGES, DOUBLE ATTACHMENT



- **Pulley for a multipurpose use** (redirection of rope, reeving, ...)
- **Aluminium body**, silver finish.
- Works on **9-12 mm** diameter Kernmantle rope.
- **Stainless steel sheave**, mounted on ball bearings.
- **Minimum breaking strength** > 40 kN.
- **Workload** : 8 kN.
- **Sheave diameter** : 45 mm.

Compliance: EN 12278:2007.

Material of components:

Body: Aluminium

Sheaves: Inox

Sheaves \varnothing :		Weight :
45 mm		0,45 kg

KRATOS SAFETY

689 Chemin du Buclay
38540 Heyrieux – FRANCE

Tel. : +33 (0)4 72 48 78 27

Fax. : +33 (0)4 72 48 58 32

www.kratossafety.com / info@kratossafety.com

HS CODE

8425 19 20

CARTON SIZE / PIECES

40 x 30 x 15 cm / 50

AET N°6192 I2 E1

Satra Technology Centre, N°0321

Wyndham Way, Telford Way, Kettering
Northamptonshire, NN16 8SD, United Kingdom

ARTICLE 11 GB07/73551

SGS United Kingdom Ltd., N°0120

Unit 202B, Worle Parkway,
Weston-super-Mare, BS22 6WA, United Kingdom