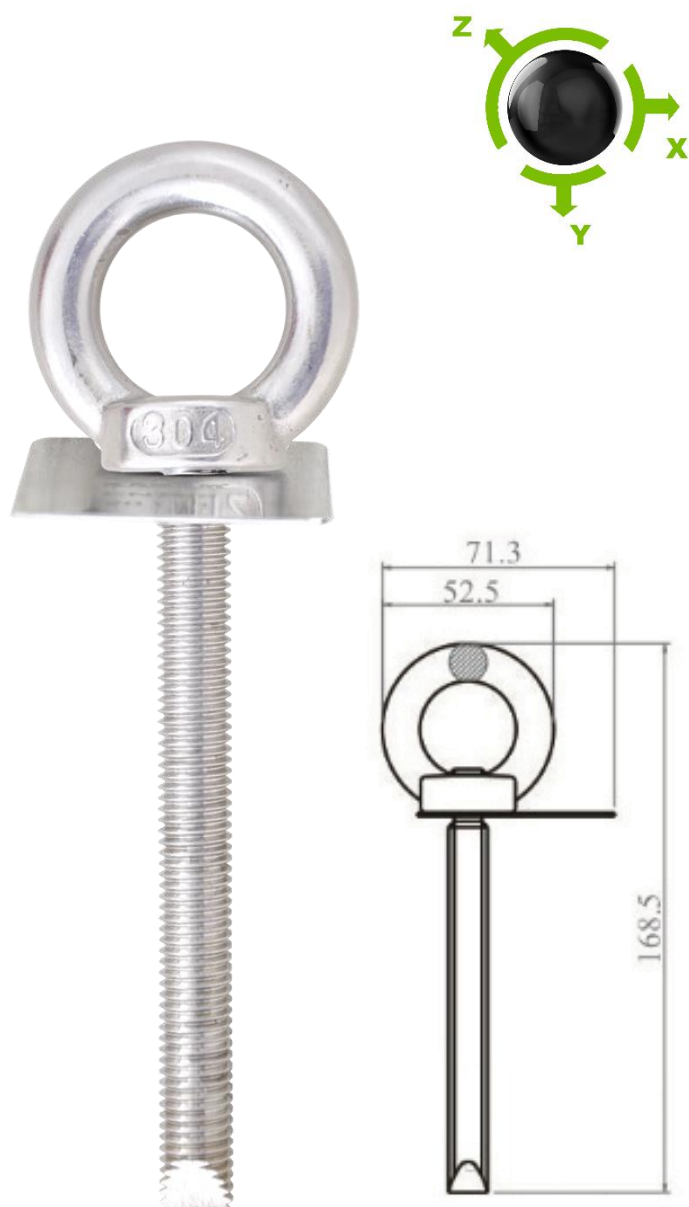

STAINLESS STEEL ANCHOR POINT WITH EYE BOLT

Designed to be fixed with a chemical ankle (not provided).

Thread length under head: 115 mm.

Diameter: M12.

Minimum breaking strength > 22 kN.

Compliance: EN795:2012 Type A.

Material:

Stainless steel 316 (A4)

Thread diam. :	CE	Weight :
M12		0.26 kg

KRATOS SAFETY
 689 Chemin du Buclay
 38540 Heyrieux – FRANCE

Tel : +33 (0)4 72 48 78 27
 Fax : +33 (0)4 72 48 58 32

www.kratossafety.com / info@kratossafety.com

HS CODE

83081010

CARTON SIZE / PIECES

40 x 30 x 15 / 50

Technical report SPC0208435 Extension 1

Satra Technology Centre, N°0321
 Wyndham Way, Telford Way, Kettering
 Northamptonshire, NN16 8SD, United Kingdom

ARTICLE 11 GB07/73551

SGS United Kingdom Ltd., N°0120
 Unit 202B, Worle Parkway,
 Weston-super-Mare, BS22 6WA, United Kingdom