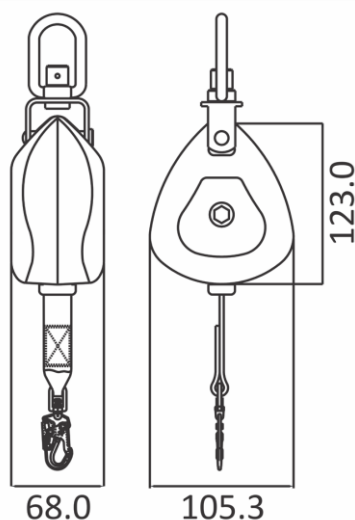

## WEBBING RETRACTABLE FALL ARRESTER, LENGTH 2 M

- Casing made up of high impact strength Polymer, to prevent breakage.
- Comes with a 25 mm polyester webbing.
- Swivel at the top and at the bottom of the device.
- Internal braking mechanism to reduce the fall arrest force to less than 6 kN.

**Minimum breaking strength > 15 kN.**

**Connectors :** Steel screw-locking karabiner FA 50 101 17, opening 18 mm, at anchorage end, and steel snap-hook FA 50 203 20, opening 20 mm, with load indicator at attachment end.

**Maxi weight for vertical use :** 140 kg.

**Average locking speed :** 0.6 m/s

**Compliance :** Conforms to EN 360 : 2002.

**Material of components :**

Protective casing: PA 6 30% fiberglass

Webbing : Polyester

Connectors : Steel

Length :		Weight :
2 m		1.44 kg

**KRATOS SAFETY**

689 Chemin du Buclay  
38540 Heyrieux – FRANCE

Tel : +33 (0)4 72 48 78 27

Fax : +33 (0)4 72 48 58 32

[www.kratossafety.com](http://www.kratossafety.com) / [info@kratossafety.com](mailto:info@kratossafety.com)

**HS CODE**

8428 90 90

**CARTON SIZE / PIECES**

60 x 40 x 24 cm / 7

AET N°6463 I 2 E 1

Satra Technology Centre, N°0321  
Wyndham Way, Telford Way, Kettering  
Northamptonshire, NN16 8SD, United Kingdom

**ARTICLE 11 GB07/73551**

SGS United Kingdom Ltd., N°0120  
Unit 202B, Worle Parkway,  
Weston-super-Mare, BS22 6WA, United Kingdom