

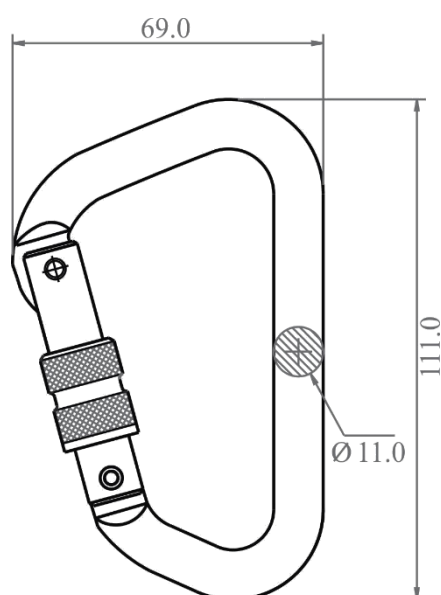

TECHNICAL SHEET FA 50 103 22B

ALUMINUM SCREW-LOCKING KARABINER, KEYLOCK TYPE



Opening :	CE	Weight:
18.5 mm		0,08 kg

KRATOS SAFETY

689 Chemin du Buclay
38540 Heyrieux – FRANCE

Tel : +33 (0)4 72 48 78 27
Fax : +33 (0)4 72 48 58 32

www.kratossafety.com / info@kratossafety.com

Aluminum screw-locking karabiner, Keylock type

- Opening: 18.5 mm
- Minimum breaking strength: 23 kN
- Compliance :
EN 362:2004 Class B

Material: Aluminum Alloy

HS CODE

7616 99 90

CARTON SIZE / PCS.

60 x 40 x 24 cm / 200

AET N°7550 I1 E1

Satra Technology Centre, N°0321
Wyndham Way, Telford Way, Kettering
Northamptonshire, NN16 8SD, United Kingdom

ARTICLE 11 GB07/73551

SGS United Kingdom Ltd., N°0120
Unit 202B, Worle Parkway,
Weston-super-Mare, BS22 6WA, United Kingdom