

MultisafeWay

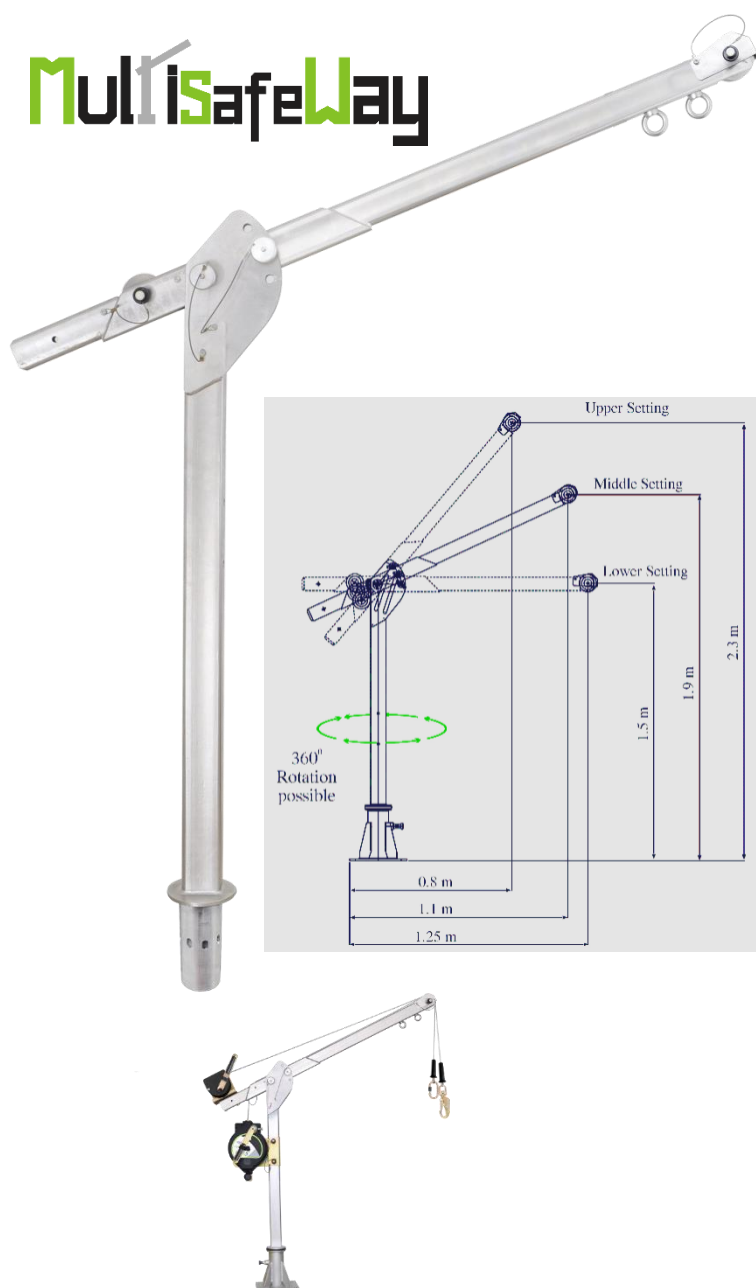

- Davit arm for access in confined spaces or works on a frontage.
- Having two eye bolts at lifting arm as attachment points.
- Provided with special stainless steel fasteners for fitting of our Winch ref. FA 60 003 00 (20 m) or ref. FA 60 023 00 (30 m).
- To be used with our retractable fall arrester with integrated rescue winch ref. FA 20 401 20 (20 m) or ref. FA 20 401 30 (30 m).

- Can swivel a complete 360 degrees on its mounted base - 8 positions.
- Lifting arm is adjustable at 3 defined points (2.3m / 1.9m / 1.5m).
- The davit arm can be moved from one mounting bracket to another.

ACCESSORIES

- 2 mounting brackets for fixing the davit arm:
 - 1 for floor mounting, ref. FA 60 022 01,
 - 1 for wall mounting, ref. FA 60 022 02.
- 2 adaptation plates for installing a retractable fall arrester with integrated winch:
 - 1 plate for 20 m retractable fall arrester, ref. FA 60 022 04,
 - 1 plate for 30 m retractable fall arrester, ref. FA 60 022 03.

- **Maximum load capacity:** 300 kg.

Compliance: EN795:2012 Type A.

- **Material:** Stainless steel.

| | | |
|------------------|---|----------------|
| Height: |  | Weight: |
| 1.50 m -> 2.30 m | | 34.87 kg |

KRATOS SAFETY

689 Chemin du Buclay
38540 Heyrieux – FRANCE

Tel : +33 (0)4 72 48 78 27

Fax : +33 (0)4 72 48 58 32

www.kratossafety.com / info@kratossafety.com

HS CODE

7610 90 10

CARTON SIZE / PIECES

168 x 34 x 25 cm / 1

CERTIFICATE OF TEST SPC0223656/1414 I1 E3

Satra Technology Centre, N°0321
Wyndham Way, Telford Way, Kettering
Northamptonshire, NN16 8SD, United Kingdom

ARTICLE 11 GB07/73551

SGS United Kingdom Ltd., N°0120
Unit 202B, Worle Parkway,
Weston-super-Mare, BS22 6WA, United Kingdom