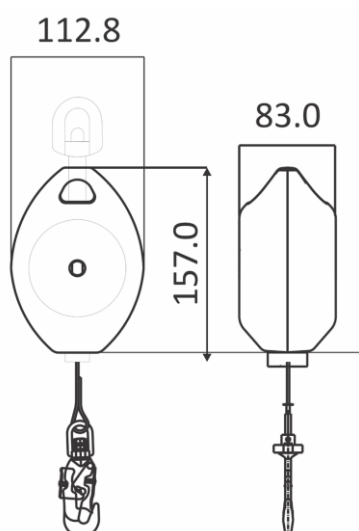

WEBBING RETRACTABLE FALL ARRESTER, LENGTH 3.50 M

- Casing made up of high impact strength Polymer, to prevent breakage.
- Comes with a 25 mm polyester webbing.
- Swivel at the top and at the bottom of the device.
- Internal braking mechanism to reduce the fall arrest force to less than 6 kN.
- Comes with an external inbuilt energy absorber.

Minimum breaking strength > 15 kN.

Connectors : Steel screw-locking karabiner FA 50 101 17, opening 18 mm, at anchorage end, and steel snap-hook FA 50 203 20, opening 20 mm, with load indicator at attachment end.

Maxi weight for horizontal use : 100 kg.

Maxi weight for vertical use : 100 kg.

Compliance : Conforms to EN 360 : 2002.

Tested and approved for horizontal use (work near sharp edges) according to VG 11.060 (Rev. 08 - 10/2014).

Material of components :

Protective casing: PA 6 30% fiberglass

Webbing : Polyester

Connectors : Steel

Length :	CE	Weight :
3.50 m		1.60 kg

KRATOS SAFETY

689 Chemin du Buclay
38540 Heyrieux – FRANCE

Tel : +33 (0)4 72 48 78 27

Fax : +33 (0)4 72 48 58 32

www.kratossafety.com / info@kratossafety.com

HS CODE

8428 90 90

CARTON SIZE / PIECES

60 x 40 x 24 cm / 6

AET N°8087 Issue 3 Extension 1

Satra Technology Centre, N°0321
Wyndham Way, Telford Way, Kettering
Northamptonshire, NN16 8SD, United Kingdom

ARTICLE 11 GB07/73551

SGS United Kingdom Ltd., N°0120
Unit 202B, Worle Parkway,
Weston-super-Mare, BS22 6WA, United Kingdom